

IFAE Light calibration system for WA105

Thorsten Lux, Juan Boix Gargallo

January 12th, 2018



Black box concept

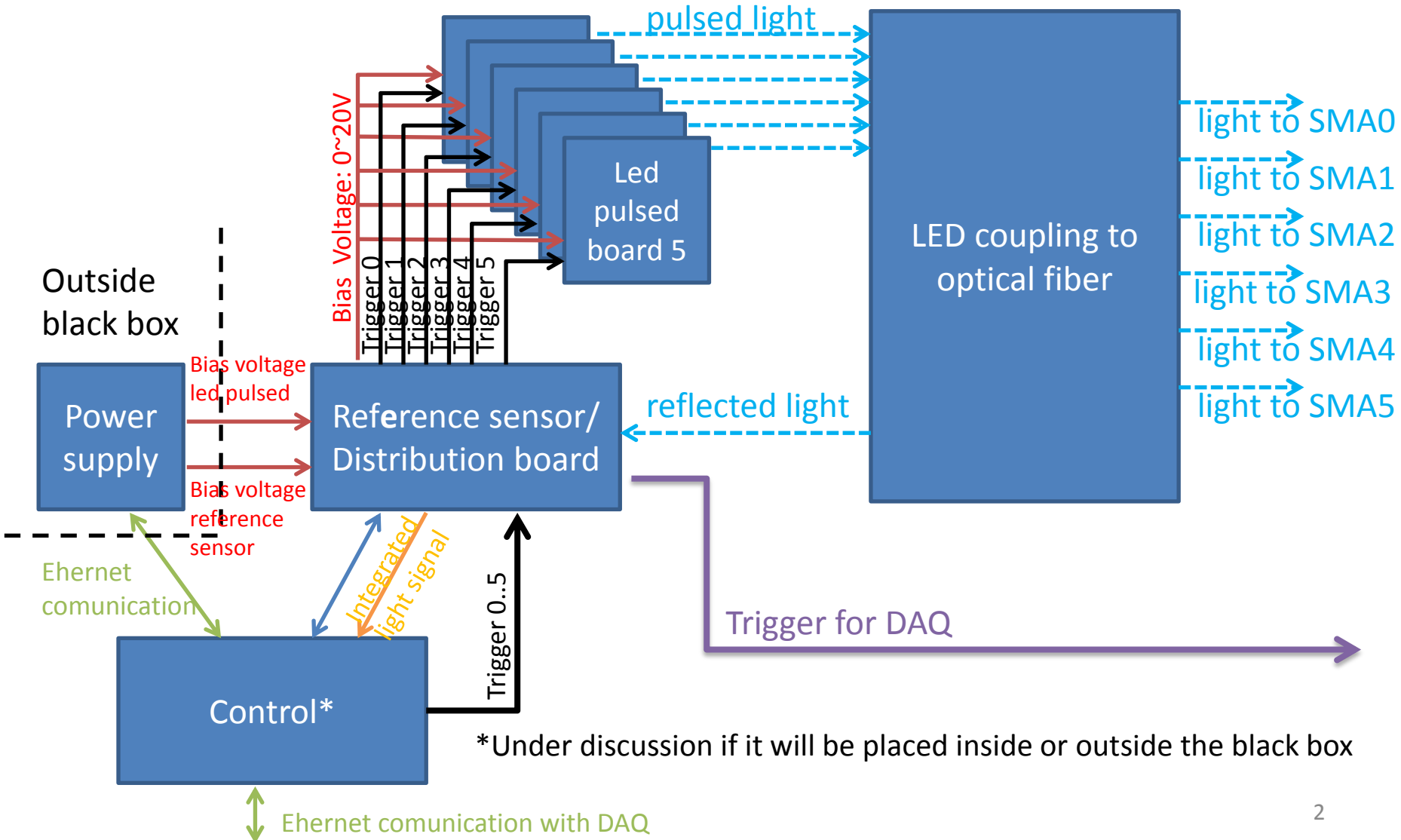

Elements status for Black Box

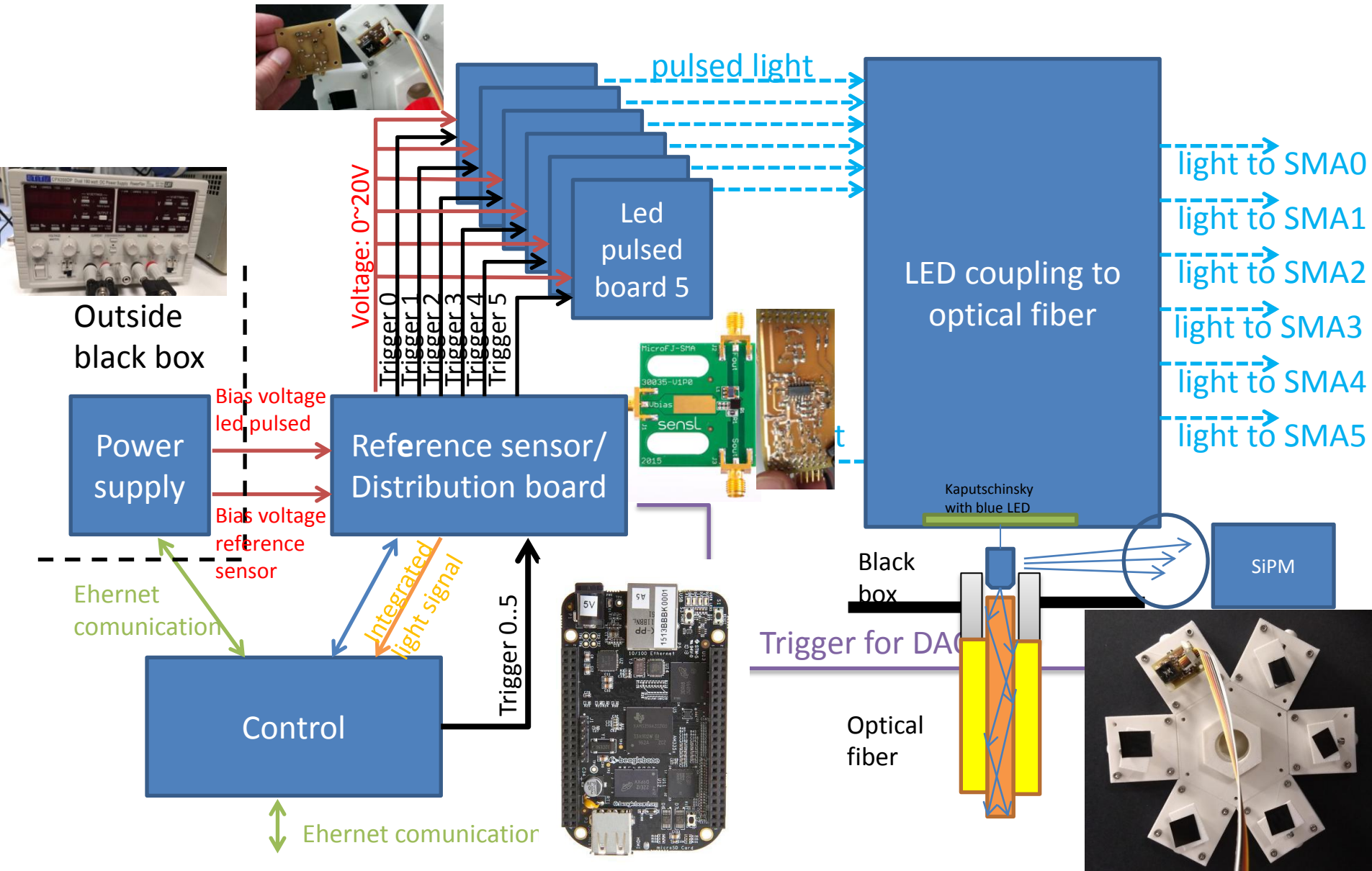

Probe of concept: Setup

Inside black box

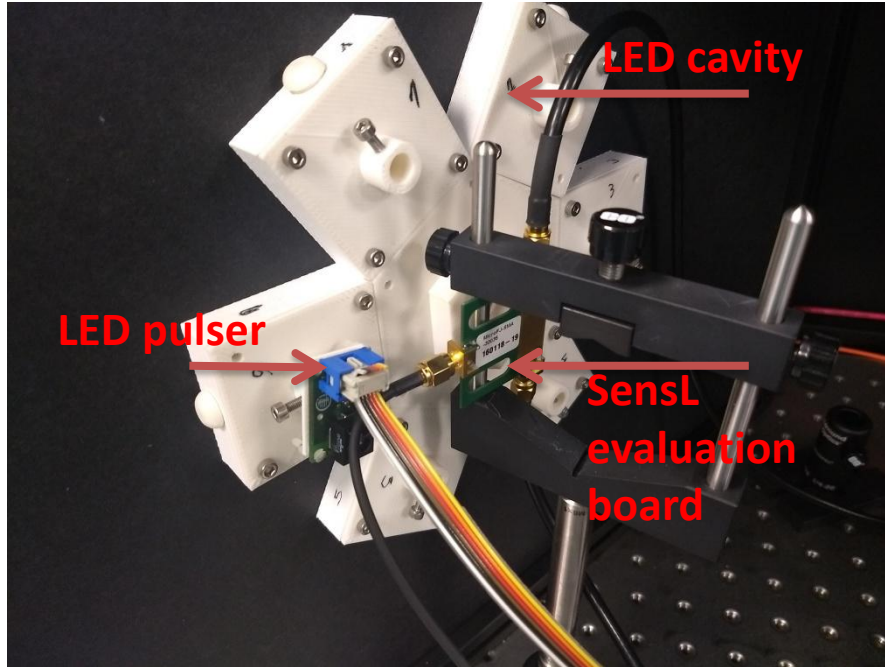

Outside black box

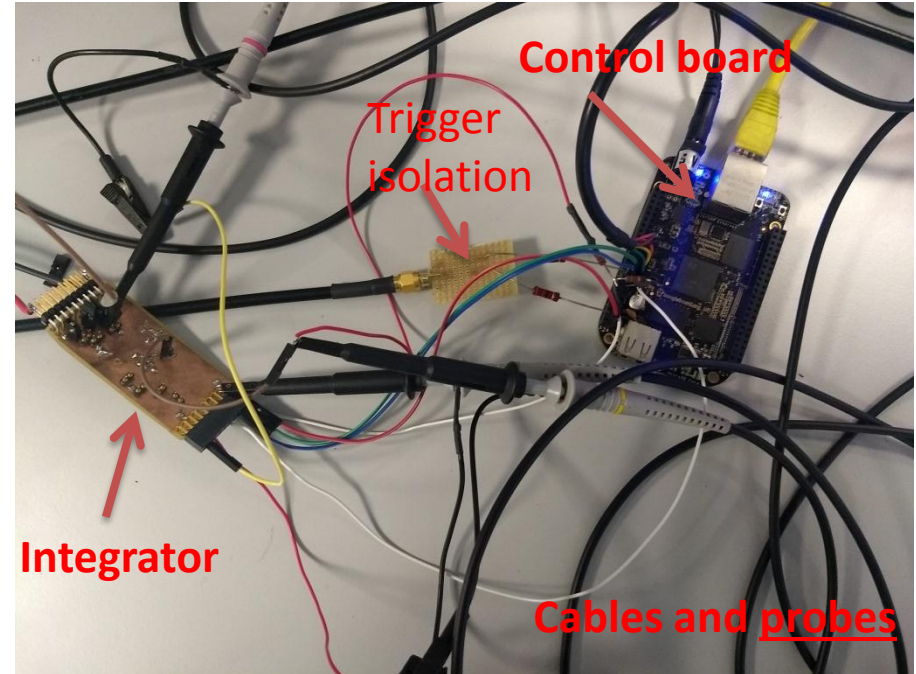

- SensL reference sensor
 - Evaluation board
 - Fast and Slow output
 - Impedance matched
 - Bias voltage 26.5 to 30.5 V

- Integrator
 - Set and Reset. Define integrator window by Beaglebone parameters
- ADC in BeagleBone
 - 12 bit
 - 200 kS/s

Probe of concept: Result

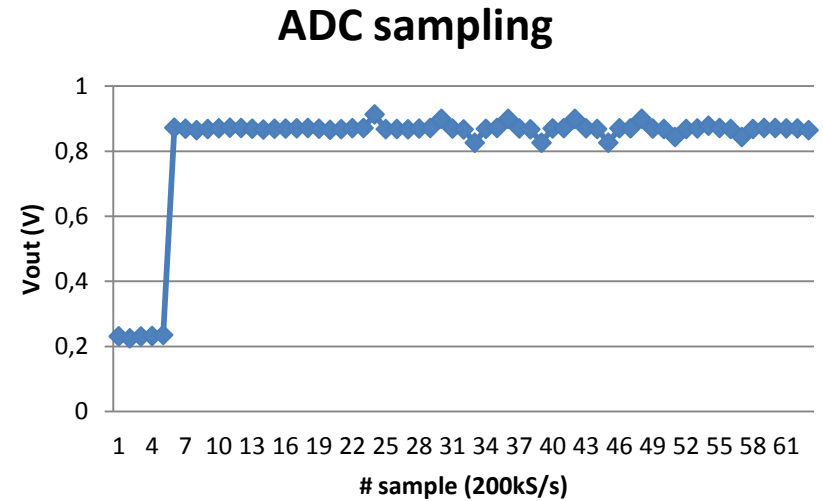
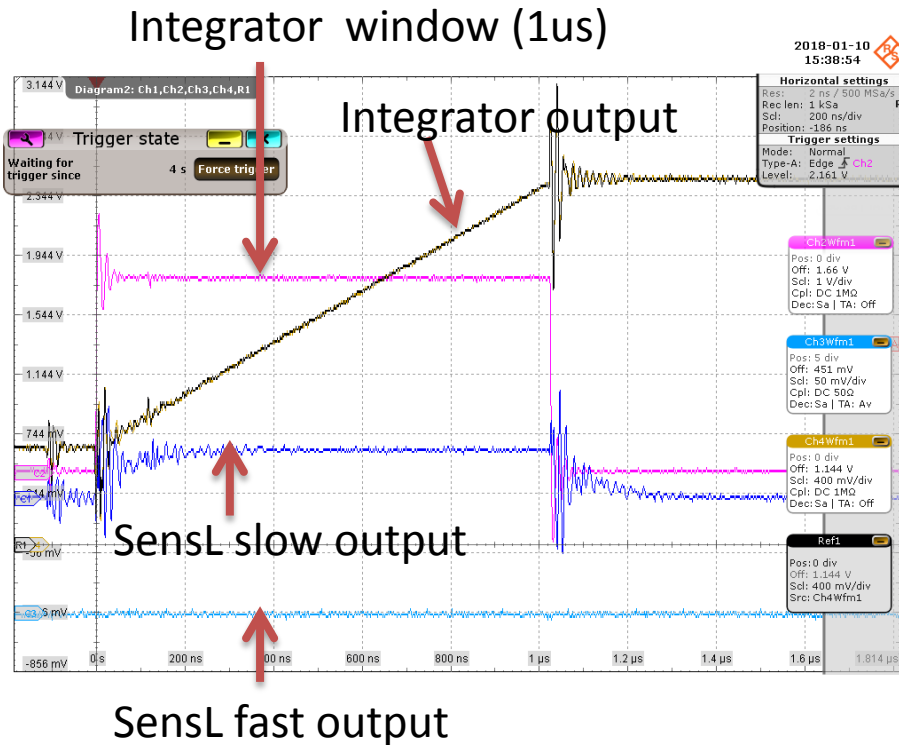

Screenshot when 0V bias is applied to LED pulser. Not response expected. Each sample ($\sim 5\mu\text{s}$) is larger than integration window ($\sim 1\mu\text{s}$).

Probe of concept: Result II

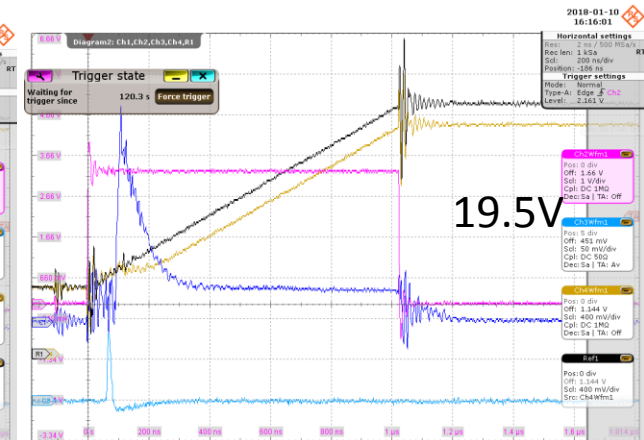
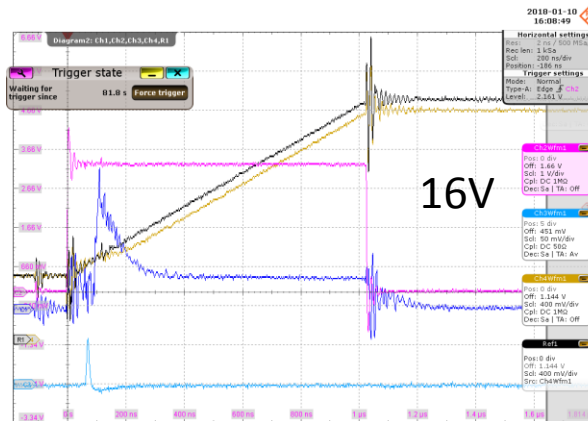
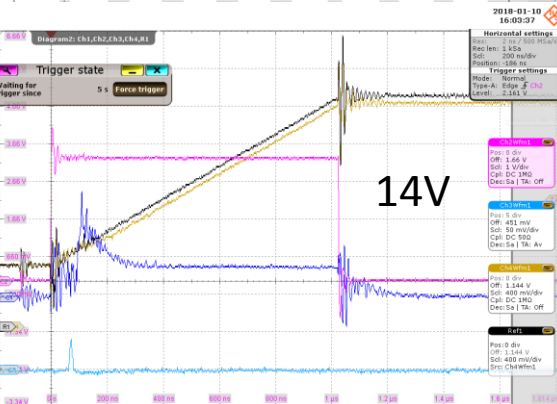
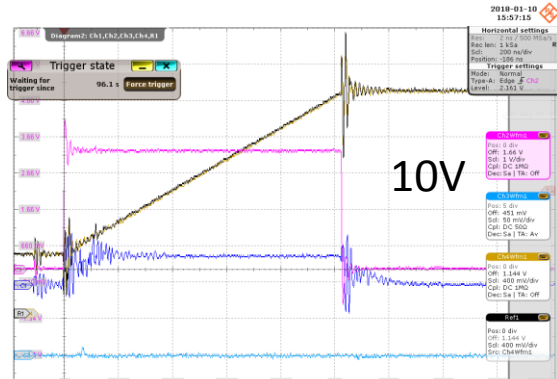
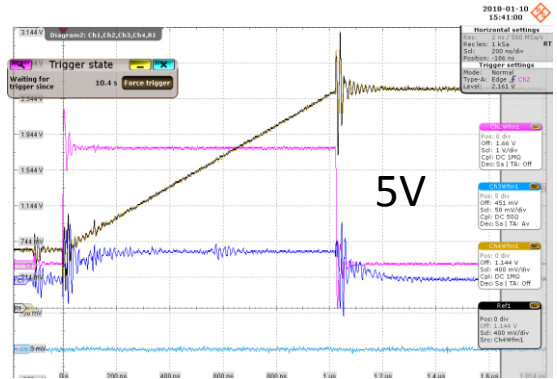

Voltage out vs power in

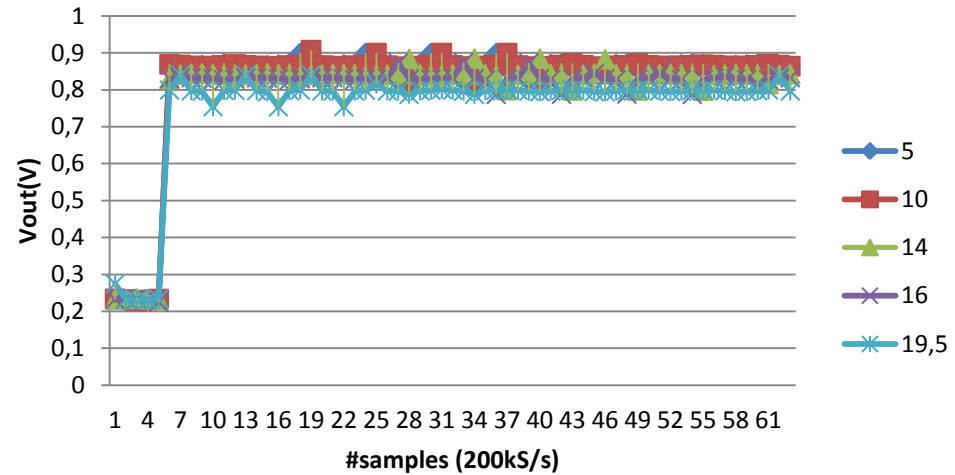

Probe of concept: Result III

Power pulse voltage vs Voltage output

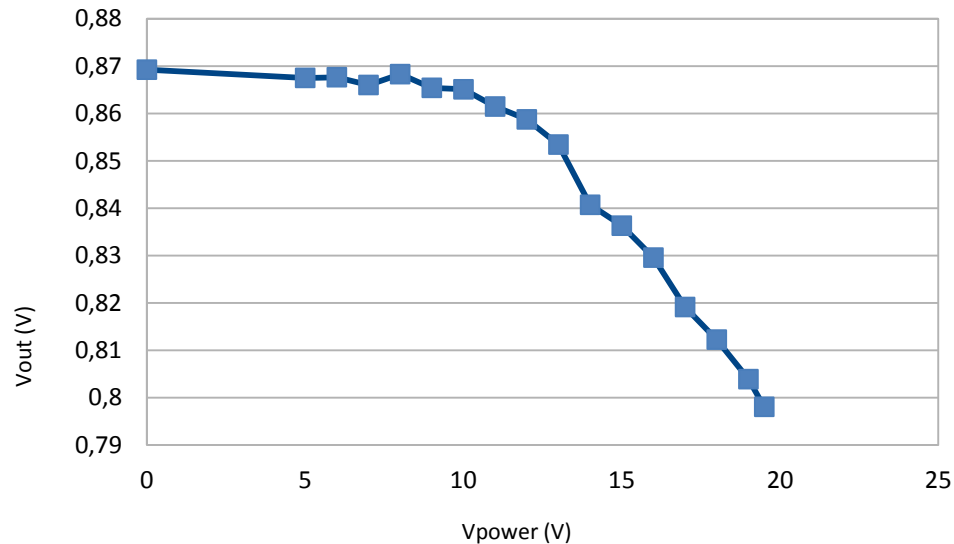

- Average samples 8 to 62
- Exponential result, like powermeter.
- Dynamic range improvement
- Noise improvement
- More statistic to confirm the result

Control user software

- Option A: Use CERN technical network
 - Ideal option.
 - Cable communication
 - Security
 - Integrate in DAQ control software.
 - Develop OPC-UA server
 - Very hard to implement.
 - Nothing exist for Beaglebone. It means time.
- Option B: Use CERN general network
 - Backup solution
 - Wifi communication
 - Inner CERN but public for every one in CERN.
 - Develop web server
 - Easy to implement
- Proposal
 - Develop option B for test and characterization at IFAE and CIEMAT.
 - Also finishing to define full functionality
 - When has to be installed at CERN?
 - If we don't have time: Install option B
 - If we have time
 - Look for alternative solution.
 - Or develop Option A: Help from Control software engineers

Summary and next steps

- Full system probe of concept is done
- Most of the hardware is finished
- Reference sensor board will developed next week
 - Schematics for diferent subsystems are done, just put schematics togheter
 - Add chip and Coax connector for TTL DAQ trigger
 - Add temperature sensor LM35 (just in case)
- While the board is manufactured, ajust the parameter to fix the integrator dynamic range (2 week)
- Asemble components in PCB (1 week)
- Test and characterization (2 weeks)
- Finalize low level control software (2 weeks)
- Ready to test in CIEMAT beginning of March.
- Develop high level control software